

TECHNICAL INSTALLATION MANUAL

UNDERGROUND OPERATOR FOR SWINGING GATES AND DOORS

INT VS

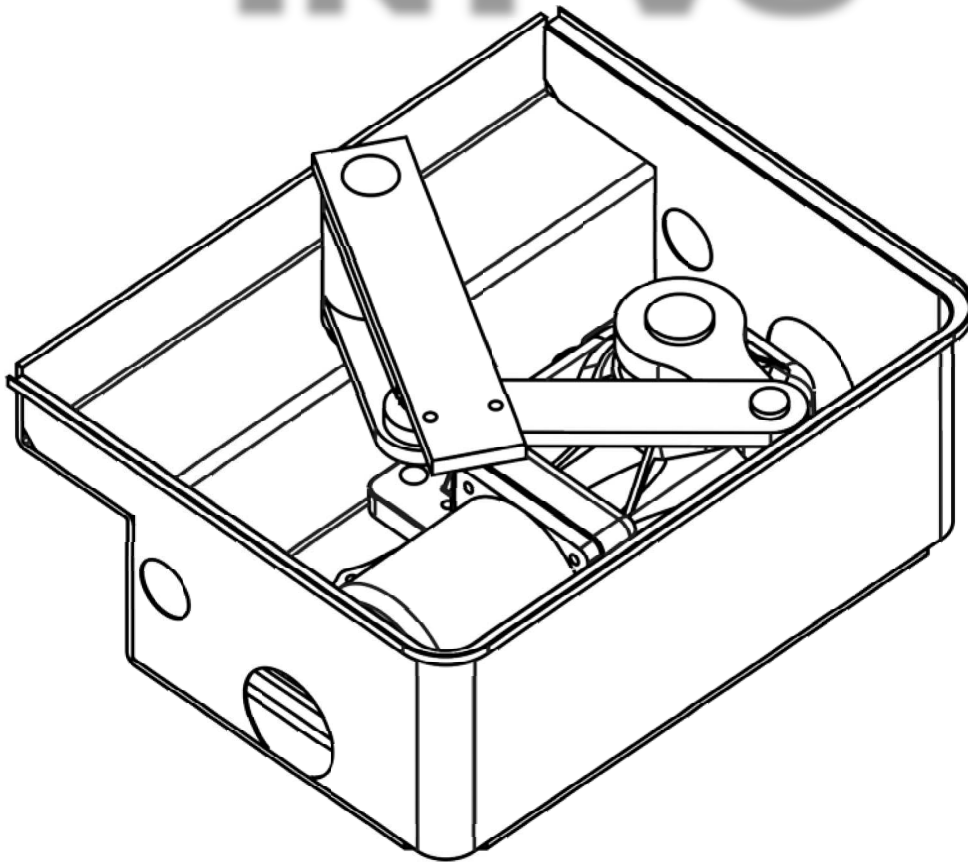

**WARNING!! Use only with control unit AS24 for UNDERGROUND
Cod. 12006666**

WARNING!! Before installing, thoroughly read this manual that is an integral part of the pack



Our products if installed by qualified personnel capable to evaluate risks, comply with norms UNI EN 12453, EN 12445



**The CE mark conforms to European directive
EEC 89/336 + 92/31 + 93/68 D.L. 04/12/1992 N. 476.**

INDEX

| | Pag. |
|---|------------------|
| PACKING CONTENTS | 2 |
| VIEW OF TYPICAL AUTOMATION AND NAMES OF COMPONENTS | 3 |
| TECHNICAL DATA..... | 3 |
| DIMENSIONS | 4 |
| TYPICAL CONNECTION AND CABLE SECTION..... | 4 |
| CONSIDERATIONS FOR INSTALLATION..... | 5 |
| INSTALLATION..... | 5-6-7-8-9 |
| TROUBLESHOOTING..... | 10 |
| SAFETY PRECAUTIONS | 11 |

PACKING CONTENTS

1- UNDERGROUND OPERATOR

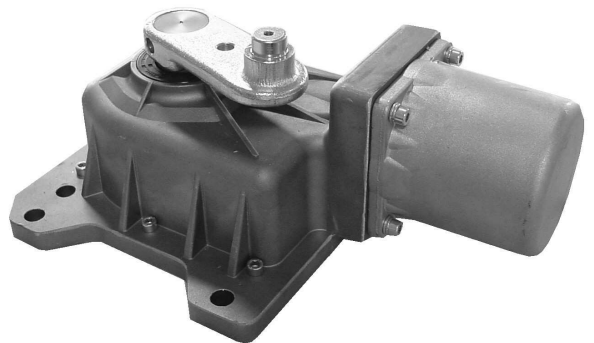

1- CONDENSER (230Vca)

VIEW OF TYPICAL AUTOMATION AND NAMES OF COMPONENTS

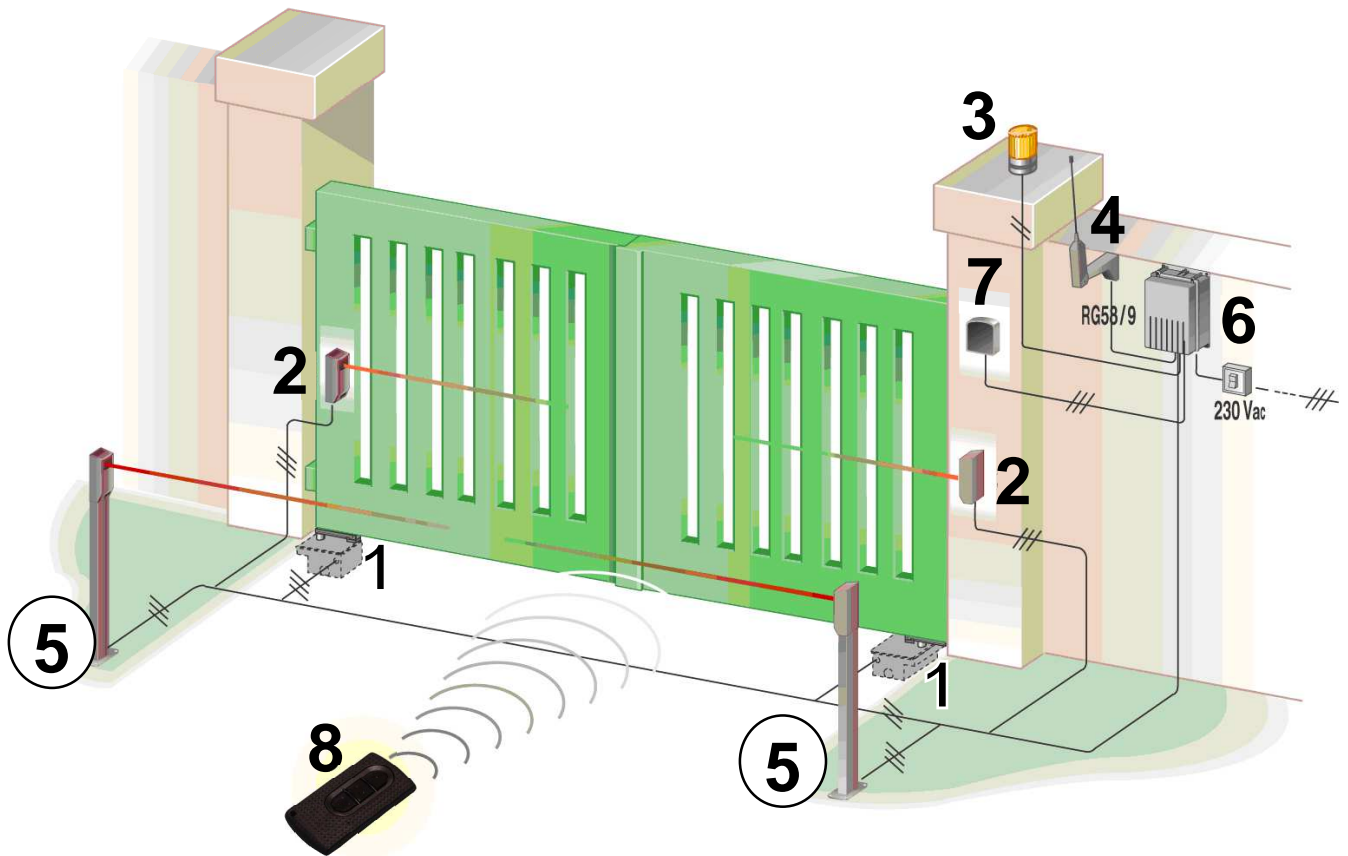

Optimal installation

- | | |
|---------------------------|----------------------------|
| 1- Operator | 5- Internal photocell |
| 2- External photocell | 6- Electronic control unit |
| 3- Flashing warning light | 7- Key-switch |
| 4- Antenna | 8- Remote control |

| TECHNICAL DATA | 24V | 230V |
|---|---------------------|---------|
| | Max. weight of gate | 400 Kg |
| Max. width of gate | 2,50 mt | |
| Motors power supply | 24 Vdc | 230 Vac |
| Motor power | 50 W | 280 W |
| Motor RPM | 1800 | 1400 |
| Condenser | / | 12,5 µF |
| Mechanical unlock for emergency manoeuvre | With key | |
| Working temperature | -20° C / +55° C | |
| weight | 10 Kg | |
| Protection rating | IP 67 | |
| Opening time 90° | 16 sec | |
| Force of thrust | 250 Nm | |
| motor current input | 3 A | 1.4 A |

DIMENSIONS

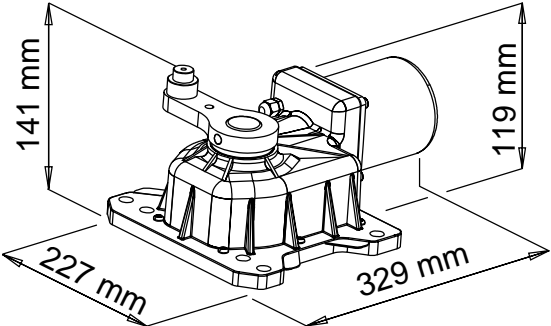
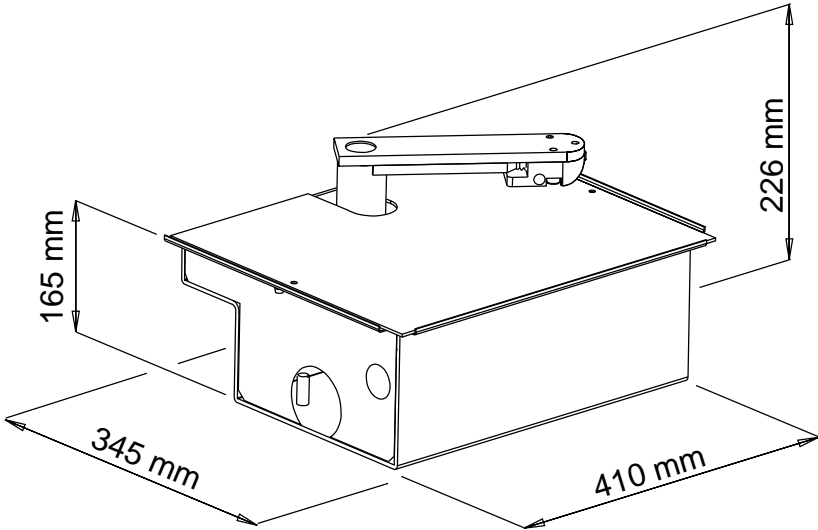

TYPICAL CONNECTION AND CABLE SECTION

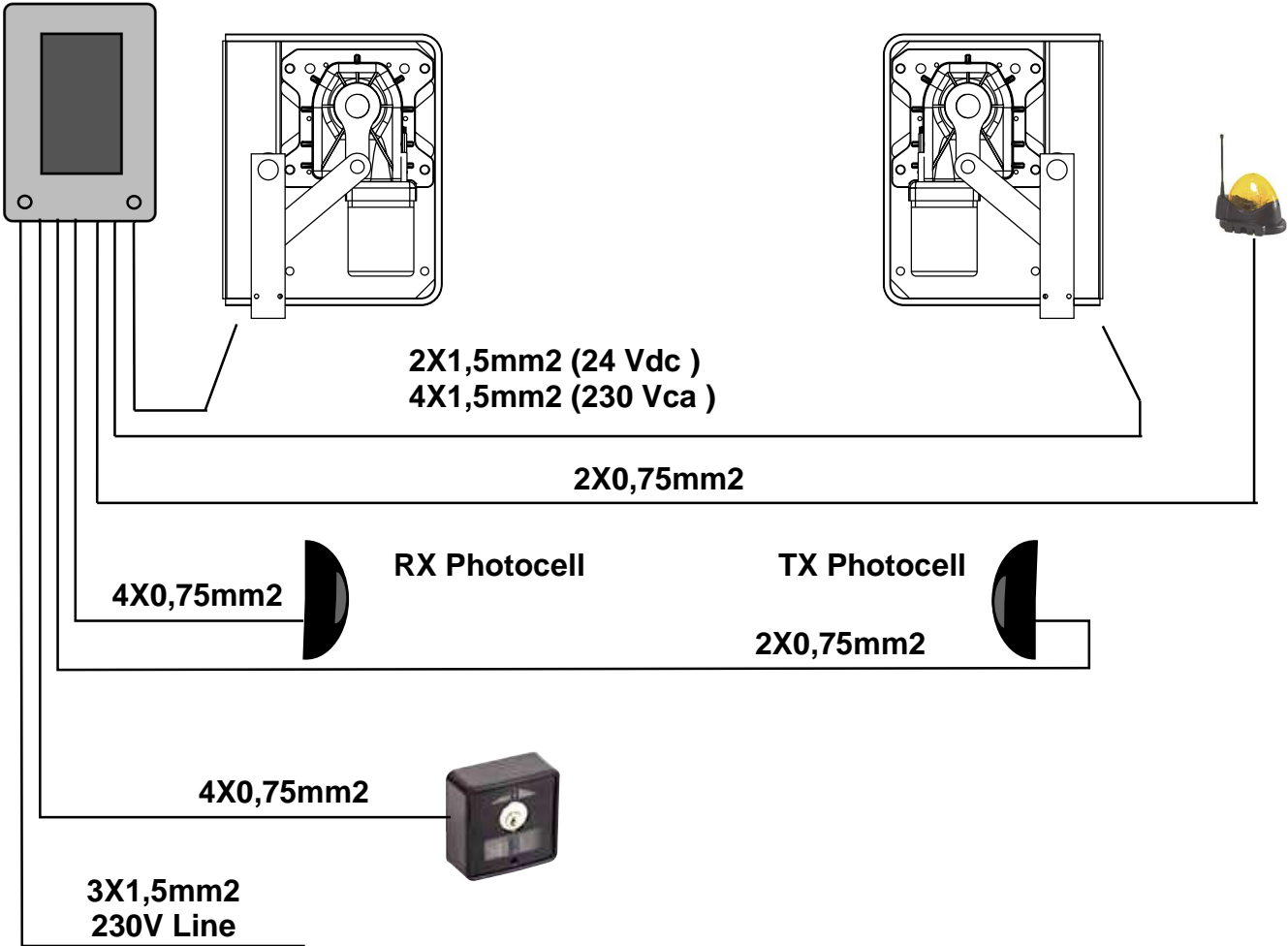

CONSIDERATIONS FOR INSTALLATION

- The installation and testing operations must be performed solely by qualified personnel in order to guarantee the proper and safe operation of the automatic gate.
- The company declines any responsibility for damage caused by incorrect installations due to incompetence and/or negligence.
- Before assembling the automatism, check that the gate is in perfect working order, hangs well on its hinges and is suitably lubricated. It must also comply with the safety standards in force in the country of installation..

INSTALLATION

Introductory note: Dig a hole big enough to hold the foundation box, calculate the required opening angle, insert the sheath for laying the power cable, make water drainage holes in the ground and cement the box solidly.

GATE WING OPENING ANGLE

Establish the required opening angle

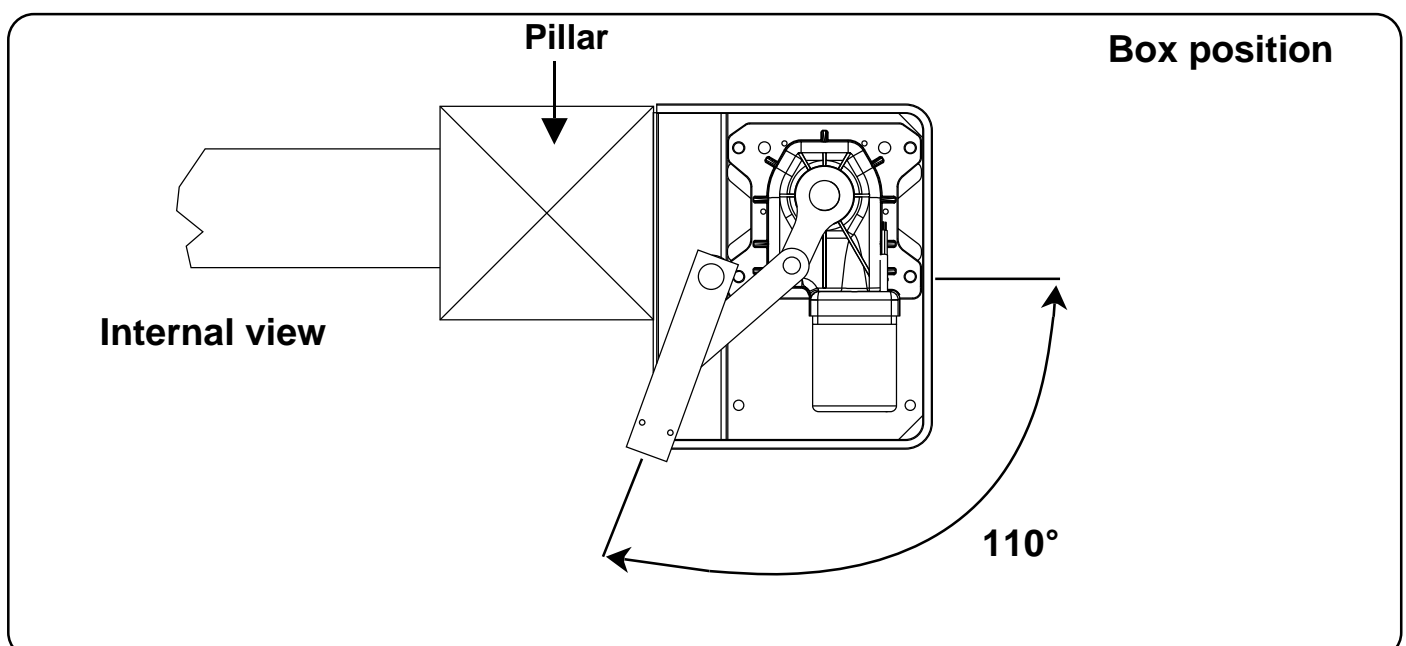
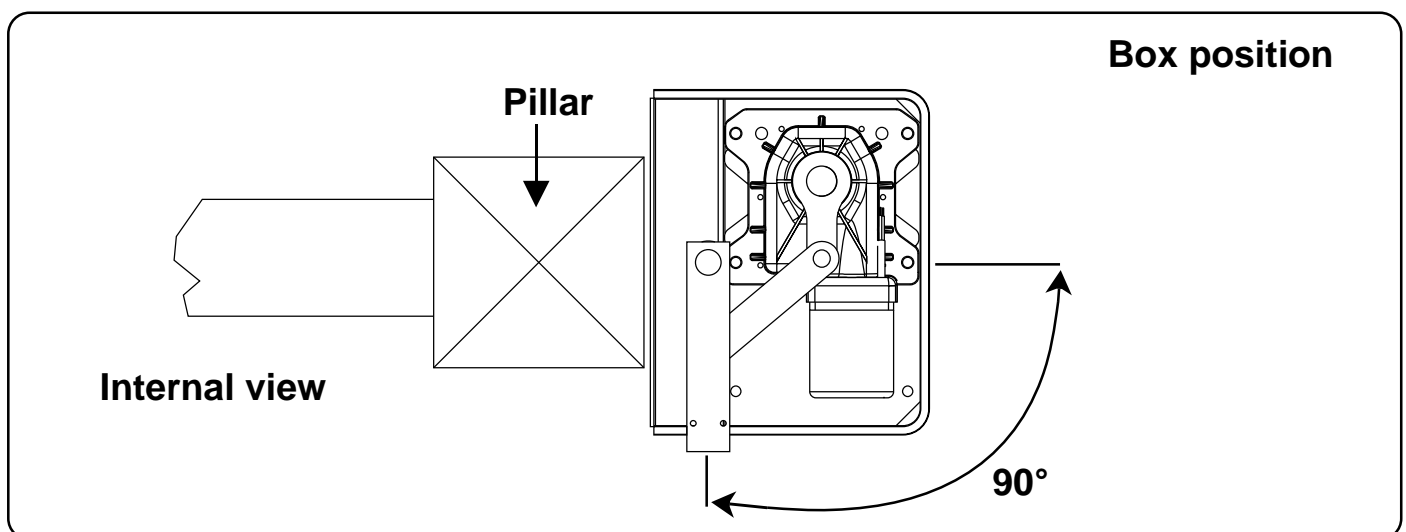

BOX INSTALLATION PROCEDURE

Dig a hole big enough to hold the box containing the operator **(C1)**

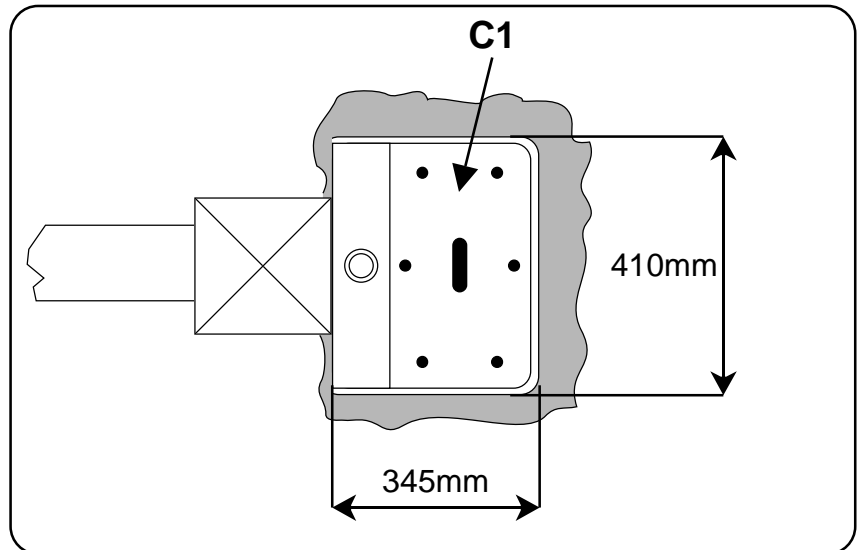

Insert the tube for water drainage in the prepared hole **(F1)**

Insert the sheath for laying the power cables **(F2)**.

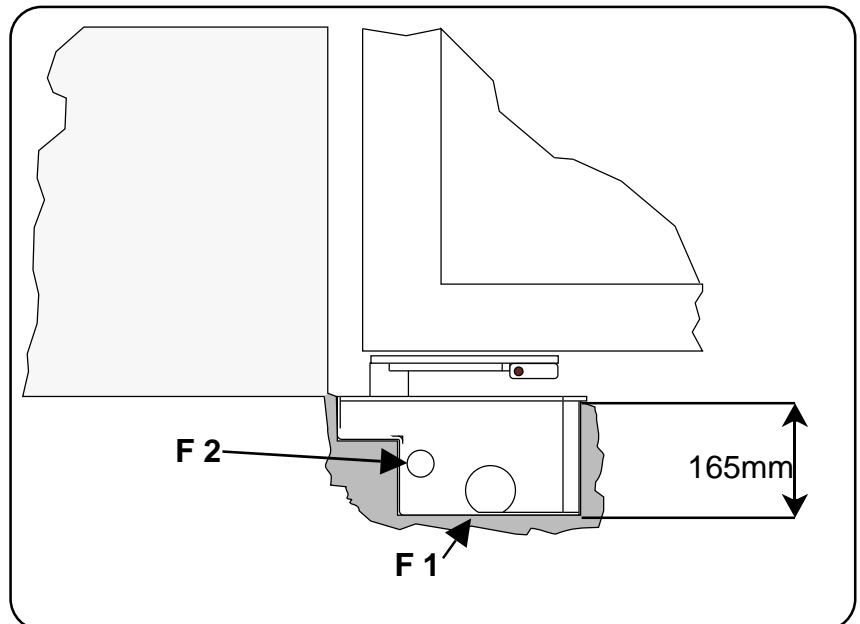

Note: while positioning the box, keep in mind the minimum distance there must be between the pillar and the centre of rotation of the gate hinge.

Cement so that the box cannot be moved, wait for it to dry and then assemble the operator and levers.

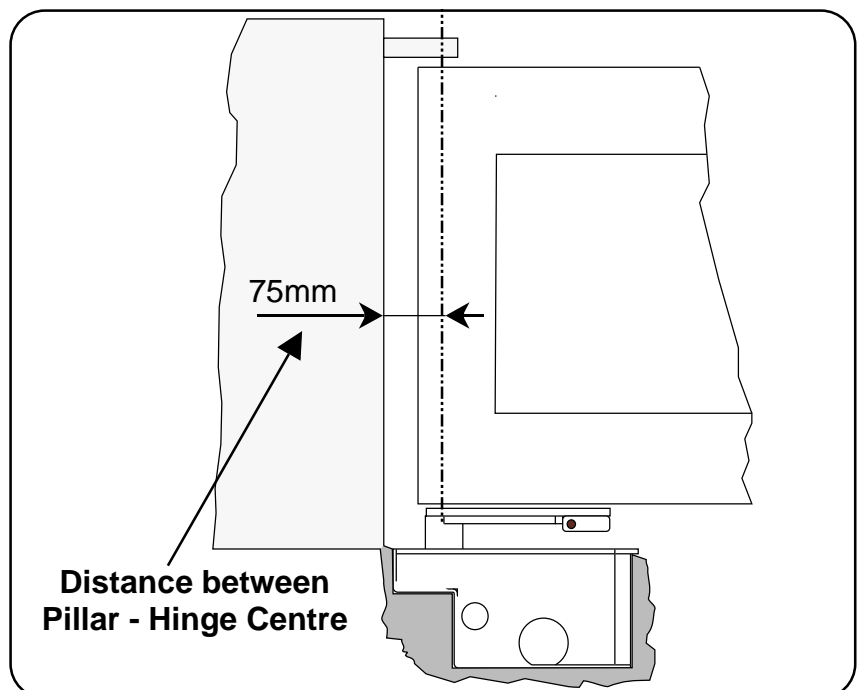

ASSEMBLING THE OPERATOR AND LEVERS

Insert the motor into the foundation case and fix it with nuts and washers supplied

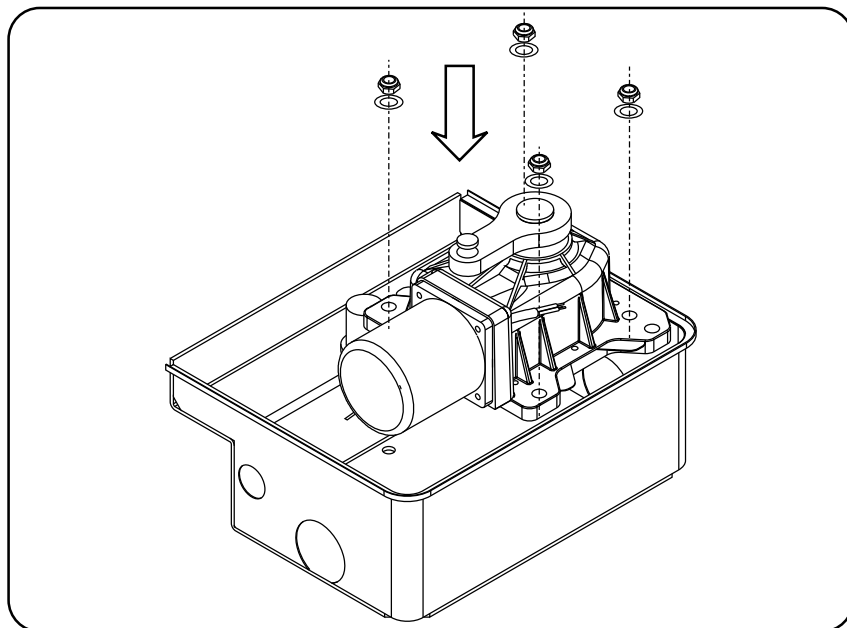

Insert the ball in the pin located on the box and fit the gate anchorage lever (L1)

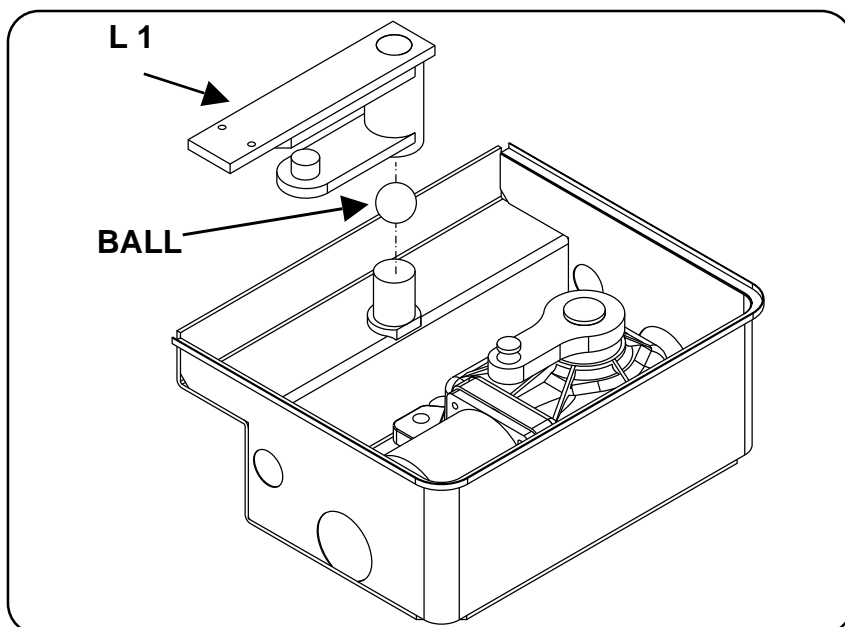

Put the connection lever (L2) between the levers (L3) and (L4) and block it with screws and washers supplied

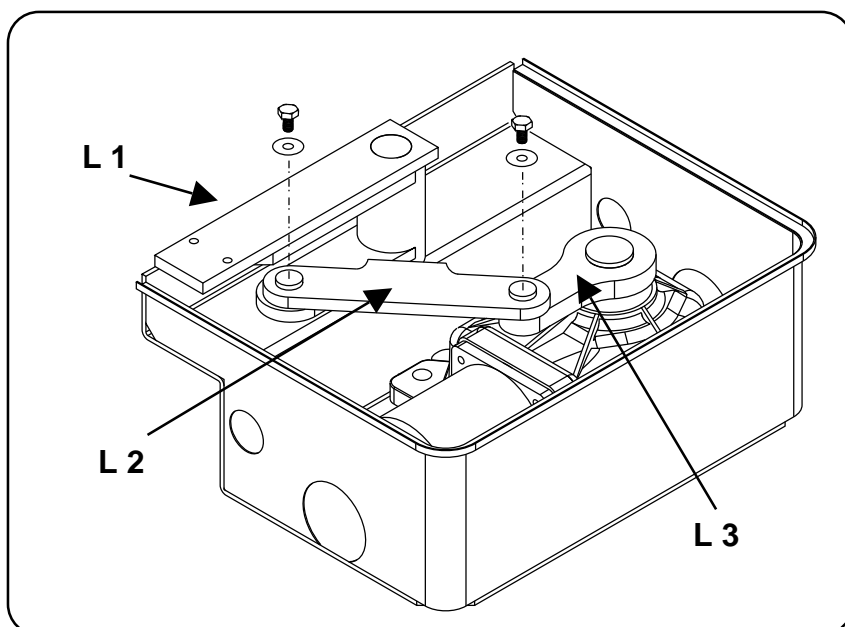

FASTENING THE OPERATOR LEVER TO THE GATE

Insert the cover and fasten it with the screws provided

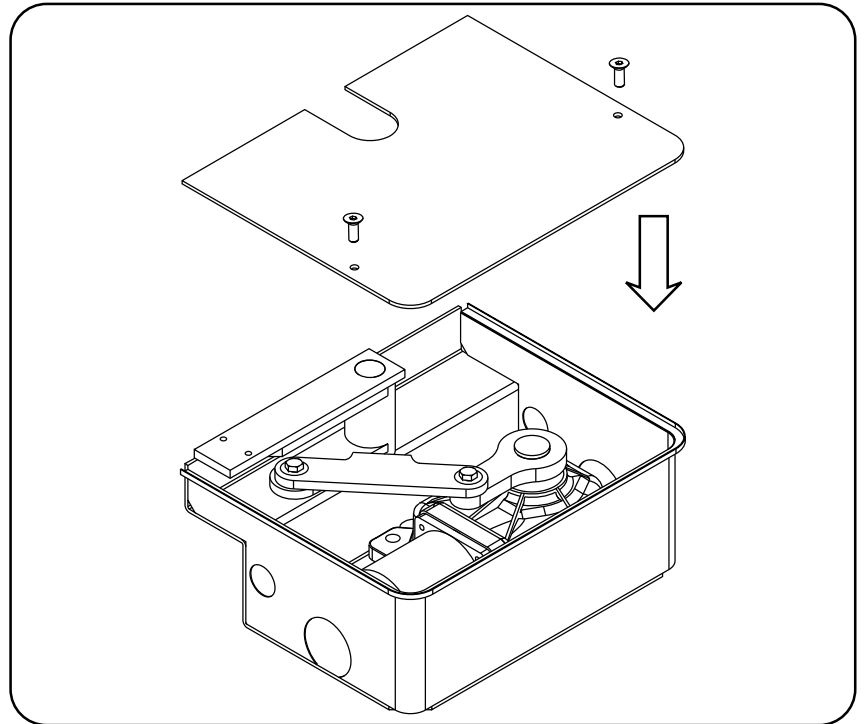

Position the gate wing and the lever (**L1**) so that they are perfectly aligned and fasten them by welding or similar.

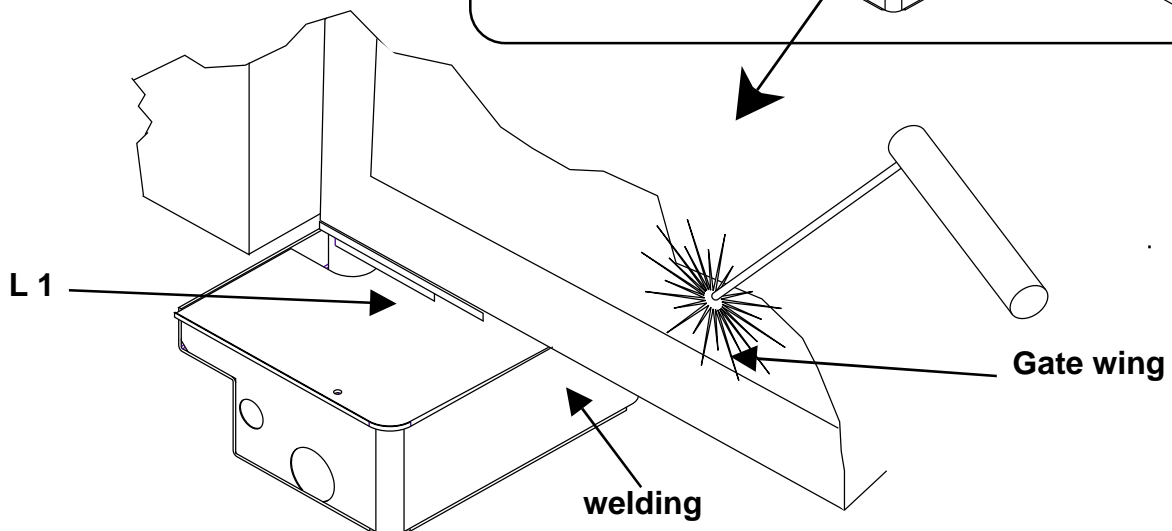
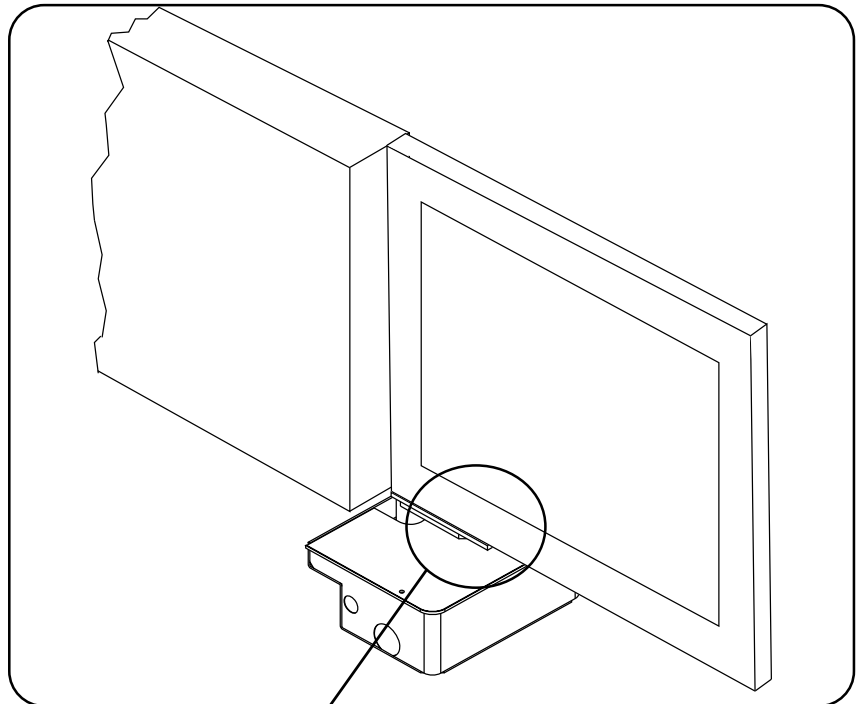

EMERGENCY RELEASE PROCEDURE

Insert the key **C** provided into the appropriate hole on the lever **L1**

Turn the key

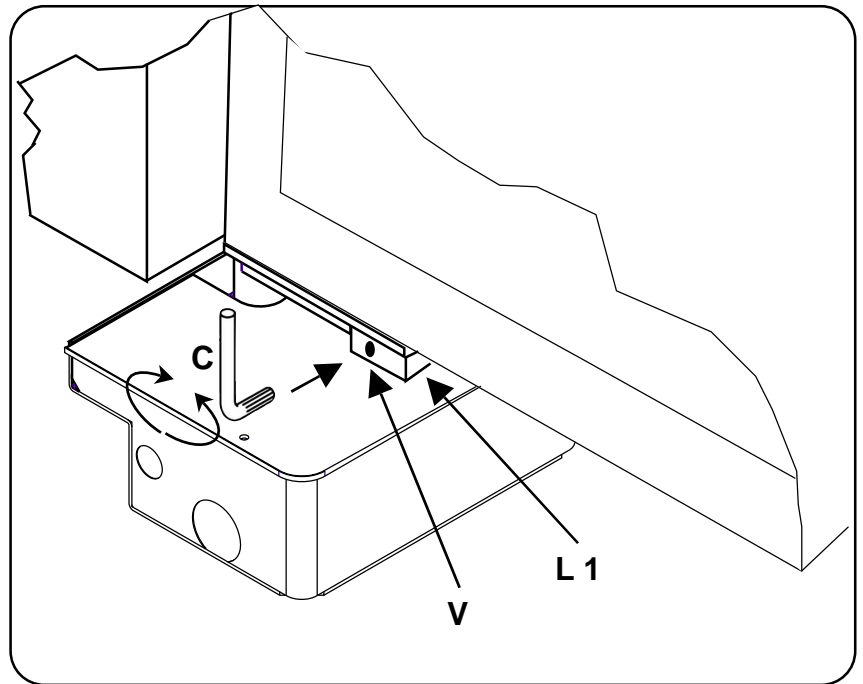

LIMIT SWITCHES ASSEMBLY (OPTIONAL)

Insert, regulate and block the mechanical limit switches in the desired position

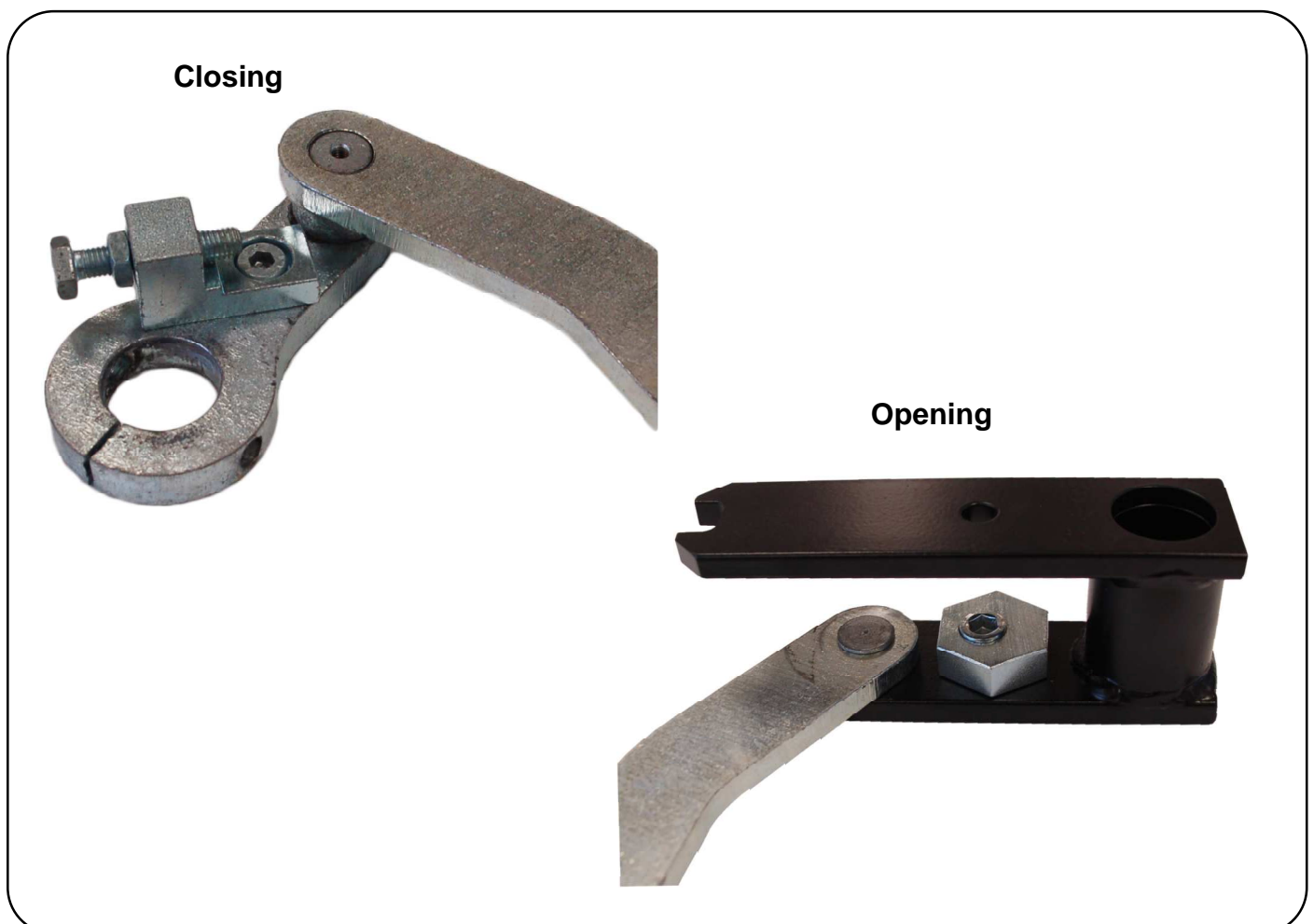

TROUBLESHOOTING

| PROBLEM | PROBABLE CAUSE | SOLUTION |
|--|--|--|
| On giving a command with the remote control or with the key-switch, the gate doesn't open or the motor doesn't start | 230 volt mains voltage absent | Check master switch |
| | Emergency STOP present | Check for any STOP selectors or commands. If not used, check jumper on STOP contact input on the control board |
| | Fuse blown | Replace with one of same value. |
| | Power cable of motor or motors not connected or faulty. | Connect the cable to appropriate terminal or replace. |
| | The photocell is not functioning or the beam is interrupted | Check the connection, remove any obstacle across the beam |
| On giving a command with the remote control, the gate doesn't open but works with the key command | The remote control has not been memorised or the battery is flat | Carry out the remote control learning procedure on the radio receiver or replace the battery with a new one.. |
| The gate starts, but stops immediately | The force of the motor or motors is insufficient | Modify the value with the FORCE trimmer on the control unit |
| One wing opens and the other closes | The connection is not correct | Invert the connection of the cable of the motor which rotates in the wrong sense |

N.B. - If the problem persists, contact your Retailer or the nearest Service Centre

SAFETY PRECAUTIONS

These warnings are an essential, integral part of the product and must be given to the user. They provide important indications on the installation, use and maintenance and must be read carefully. This form must be preserved and passed on to subsequent users of the system. The incorrect installation or improper use of the product may be dangerous.

INSTALLATION INSTRUCTIONS

- The installation must be performed by professionally skilled personnel and in compliance with current local, state, national and European legislation.
- Before beginning the installation, check the integrity of the product.
- The laying of cables, electrical connections and adjustments must be workmanlike performed.
- The packing materials (cardboard, plastic, polystyrene, etc.) are a potential hazard and should be disposed of correctly and not left within reach of children.
- Do not install the product in potentially explosive environments or environments disturbed by electromagnetic fields. The presence of inflammable gases or fumes is a grave danger to safety.
- Set up a safety device for overvoltage, a disconnecting and/or differential switch suitable for the product and conforming to current standards.
- The manufacturer declines any and all responsibility for product integrity, safety and operation in the event incompatible devices and/or components are installed.
- Solely original spare parts should be used for repairs and replacements.
- The installer must provide all the information relating to the operation, maintenance and use of the individual parts, components and system as a whole.

WARNINGS FOR THE USER

- Read the instructions and enclosed documentation carefully.
- The product must be used for the express purpose for which it was designed. Any other use is considered improper and therefore hazardous. In addition, the information given in this document and in the enclosed documentation may be subject to modifications without prior notice. It is given as an indication only for product application. The company declines any responsibility for the above.
- Keep products, devices, documentation and anything else provided out of reach of children. In the event of maintenance, cleaning, breakdown or faulty operation of the product, cut off the power and do not attempt to operate on the product. Contact solely the professionally skilled personnel responsible for these operations. Failure to adhere to the above indications may be dangerous.

**The data and images are for guidance only
reserves the right to change at any time characteristics of the products described in its
sole discretion, without notice.**