

TECNO-CAT NEW Chain Barrier

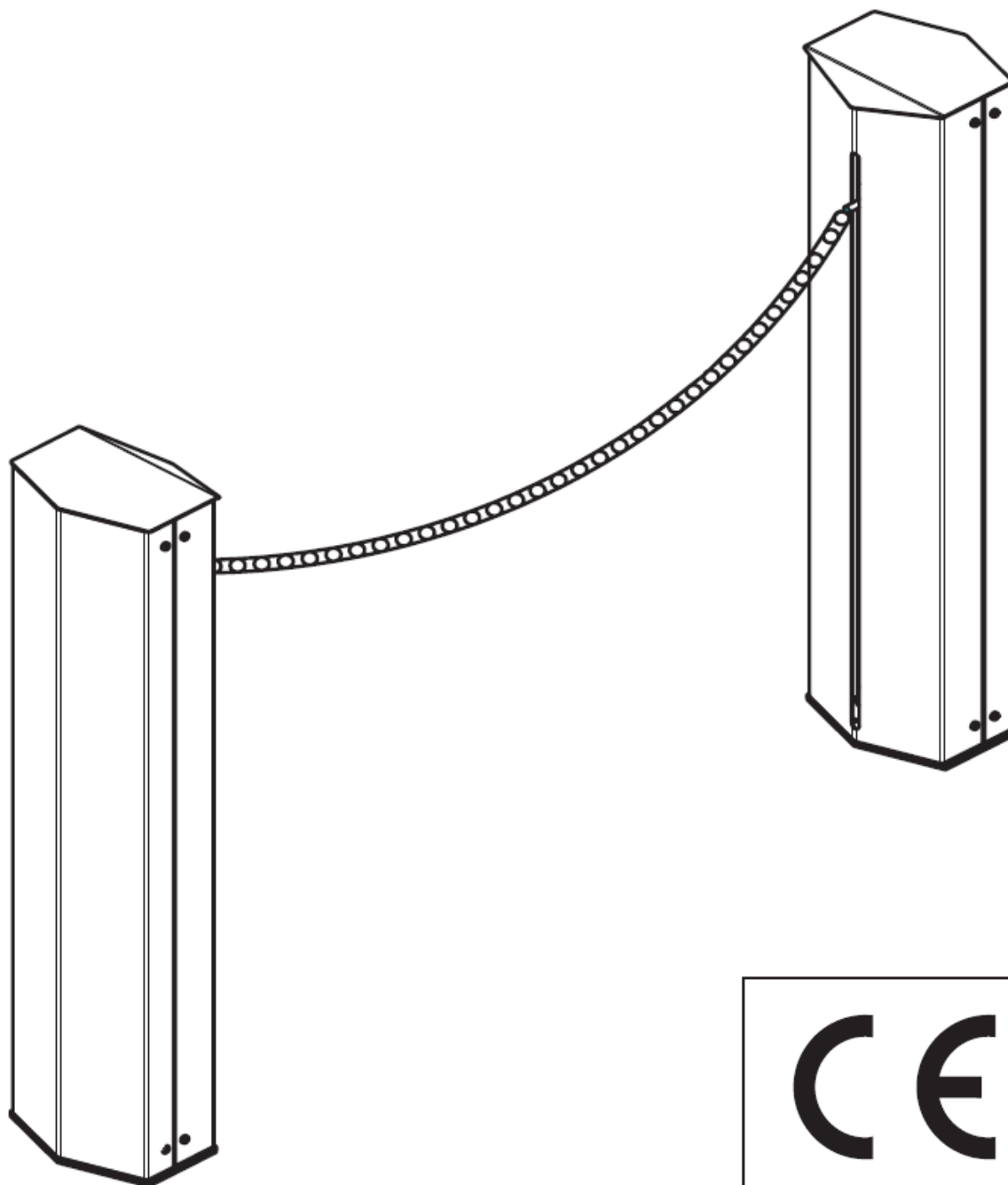

1. Lay-out

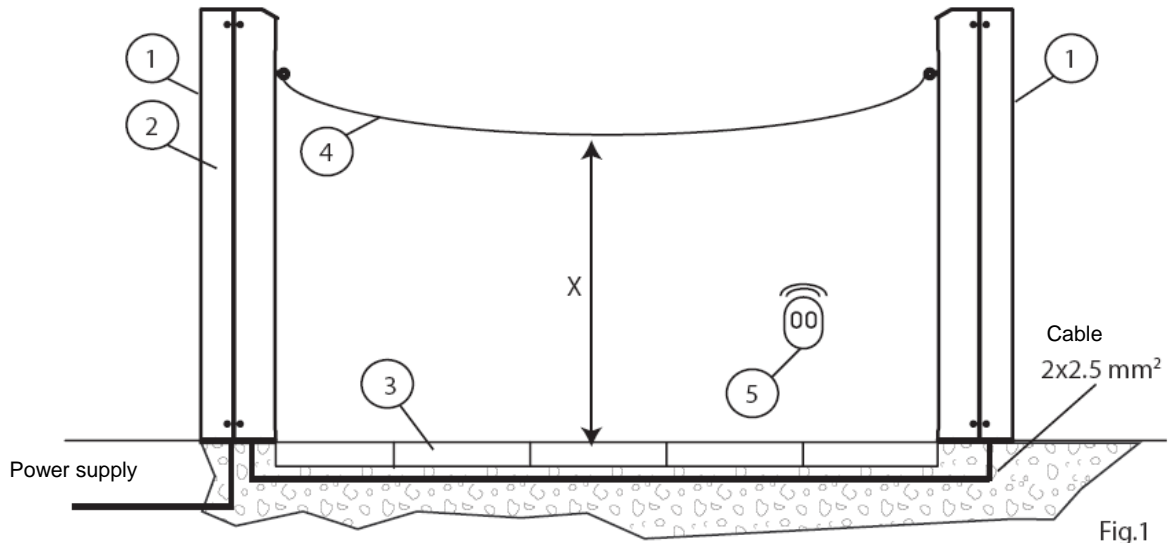

Fig.1

Length of the chain (m)	4	6	8	10	12	14	16	18	20
Relative height in the middle X (cm)	75	70	65	60	55	50	45	40	35

Description:

- [1] Chain barrier Tecno Cat New
- [2] Control unit
- [3] Profile for the chain below ground
- [4] Chain
- [5] Radio transmitter

Attention: The value in the table has been determined using a chain of 400 grammes/meter

2. Description and dimension of the column

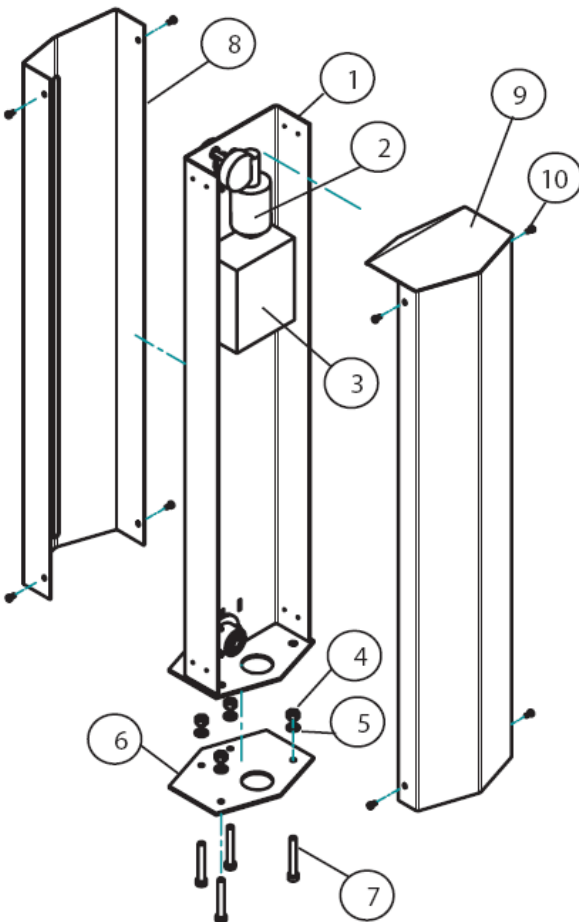

Description:

- [1] Column
- [2] Gearmotor with encoder
- [3] Control unit
- [4] Autoblocking nut M10
- [5] Washer 20x10
- [6] Backing plate
- [7] Screw M10x70
- [8] Anterior cover
- [9] Posterior cover
- [10] Closing screw M5x10

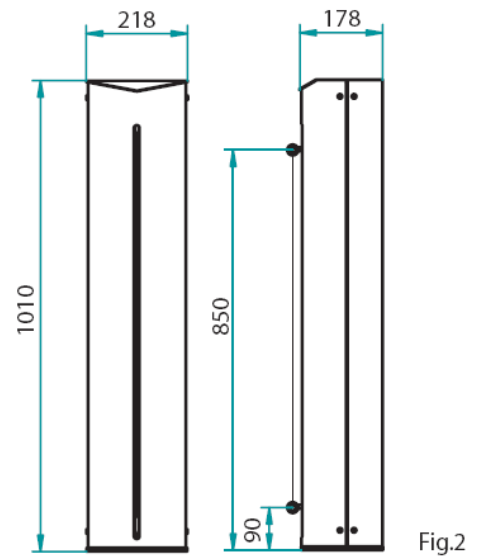

Fig.2

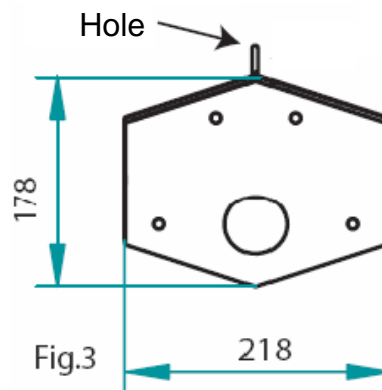

Fig.3

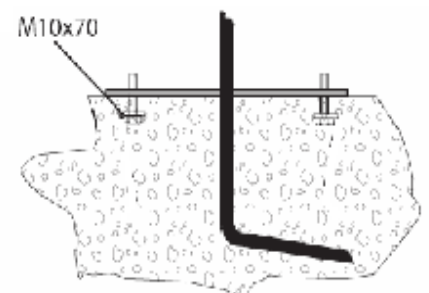

Fig.4

3. Installation

All measures are expressed in millimeters unless otherwise indicated.

3.1. Preliminary controls

1. Control the stability and solidity of the zone where the columns are going to be fixed.
2. Use an omnipolar interrupter with contact distance of at least 3mm.
3. The connection to the power supply must be separated than the connections to the security and commanding devices.

3.2. Installation of the column (Fig. 1, Fig. 3, Fig. 4)

1. Screw in for 1,5 – 2,0 cm the 4 screws M10x70 in dotation to the base.
2. Place than the base on the previously prepared base of cement (Fig.3)
3. The upper part of the base should be clean and perfectly horizontal.
4. Pass the plastic tubes of the cables through the central opening on the base and check again the stability of the base.
5. Unscrewing the 8 screws [10] take off the frontal [8] and the rear cover [9] of the column (Fig. 4)
6. Place now the column structure on the base.
7. Fix now the column to the base with the 4 washers [5] and 4 nuts [4].
8. Fix the frontal covers [8] of both columns with 4 screws [10].
9. Now you can fix the chain to the apposite holes on both columns respecting the level X in the middle of the chain barrier indicated at the table on page 1 (Fig. 5)

3.3. Electrical connections

Please refer to the instructions of the control unit ACTION for the chain barrier (code: 61622349).

4. Maintenance plan (every 6 months)

1. Cut the power supply off or disconnect the batteries if present. Clean and grease the guide and the pignons internally.
2. See if there are weared parts and replace these if necessary
3. Grease the internal transmitting chain.
4. Check the fixation nuts
5. Control the electrical connections
6. Supply the power again
7. Check out the correct functioning of the obstacle recognition (encoder system)
8. Check out the correct functioning of all and of the security commands

5. CONNECTION OF THE BREAKING JOINT



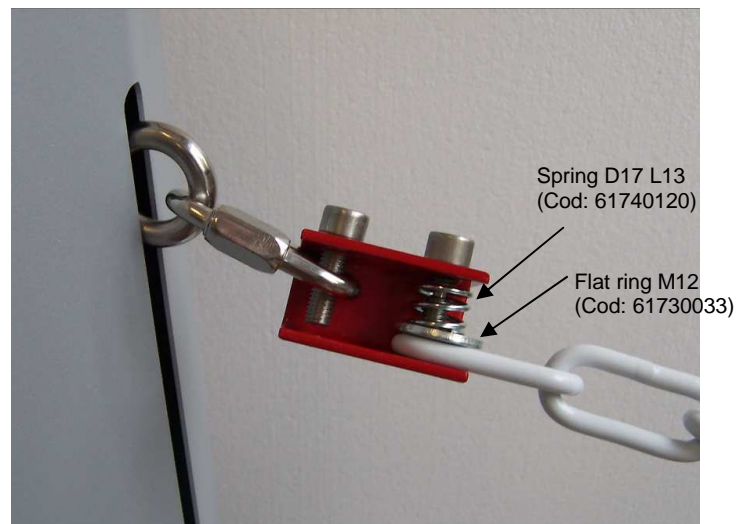
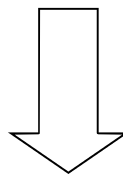
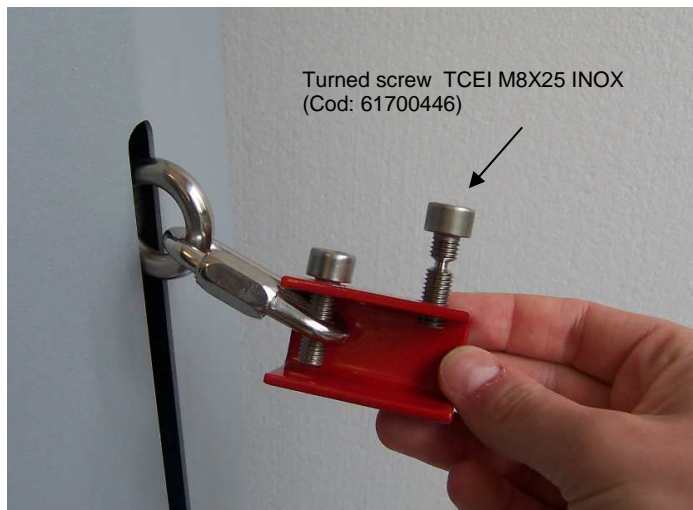

6. Technical Data

Power supply:	230 Vac 50 Hz	120 Vac 60 Hz
Current Draw:	1.0 A	1.0 A
Motor Power:	60 W	60 W
Force:	645 Nm	645 Nm
Service:	50 %	50 %
Protection Degree:	IP 34	IP 34
Lubrication:	Permanent	Permanent
Weight:	25 Kg	25 Kg
Max chain weight:	8.5Kg	8.5Kg

GUARANTEE - In compliance with legislation, the manufacturer's guarantee is valid from the date stamped on the product and is restricted to the repair or free replacement of the parts accepted by the manufacturer as being defective due to poor quality materials or manufacturing defects. The guarantee does not cover damage or defects caused by external agents, faulty maintenance, overloading, natural wear and tear, choice of incorrect product, assembly errors, or any other cause not imputable to the manufacturer. Products that have been misused will not be guaranteed or repaired. Printed specifications are only indicative. The manufacturer does not accept any responsibility for range reductions or malfunctions caused by environmental interference. The manufacturer's responsibility for damage caused to persons resulting from accidents of any nature caused by our defective products, are only those responsibilities that come under Italian law.