



ACTION CONTROL UNIT FOR BASCULE DOOR

INSTRUCTIONS FOR INSTALLATION

1. Introduction

Action is a control unit advisable to the moving of bascule doors moved by motor of 24 Vcc. The coexistence of various types of safeties, such as, for example, the control of the current absorbed from the motor and the control of the velocity, allows a rapid intervention for the anti-squashing prevention. The operation of the position by an encoder installed on the motor, allows the use of it in absence of electrical limit switches. Action has inputs dedicated to the connection of the limit switches, of the step by step button, of the pedestrian button, photodispositives input and security stop input, besides the output for flashing light 24 Vac. The central allows the regulation by trimmer of the automatic reclosing and the force exercised by the motor. Action can control motors with a maximum waste of 7A on 24 ÷ 30 Vcc.

2. Configuration

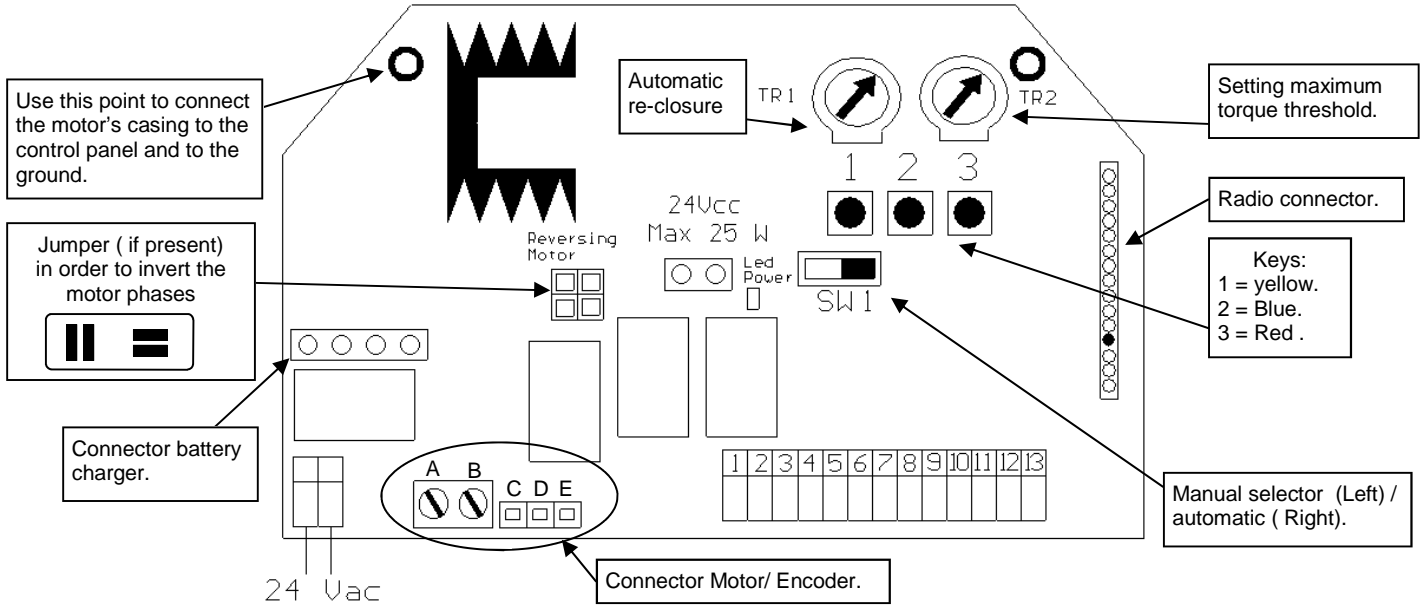

3. Electrical connections

| Terminal | Function | Setting |
|----------|---|----------------------|
| 1 - 2 | Flashing signal output | OUT: 24 Vac 25 W MAX |
| 3 | Positive power supply TX & RX photocell | OUT: +24Vcc |
| 4 | Negative power supply TX photocell | OUT: GND TX |
| 5 | Negative power supply RX photocell and common button and safety | OUT: GND RX Common |
| 6 | Stop closure button input | Normally closed (NC) |
| 7 | Stop open button input | Normally closed (NC) |
| 8 | STOP button input | Normally closed (NC) |
| 9 | RX photocell contact input | Normally closed (NC) |
| 10 | Pedestrian button input | Normally open (NO) |
| 11 | Relay button input | Normally open (NO) |
| 12 | Antenna screen input | GND |
| 13 | Antenna input | Antenna |

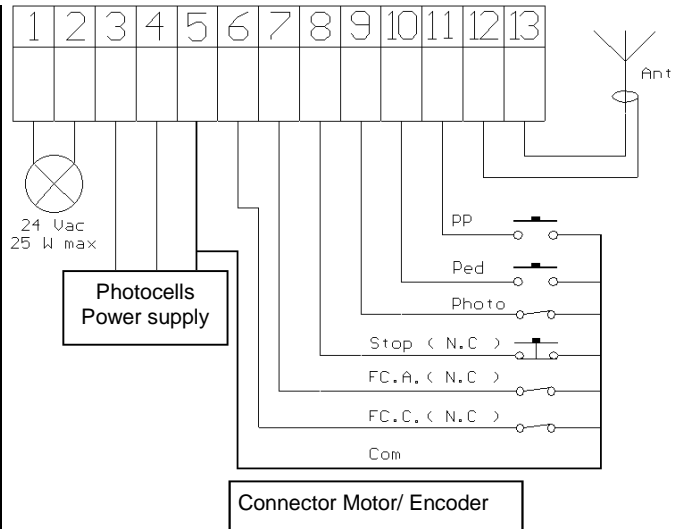

Example of connection

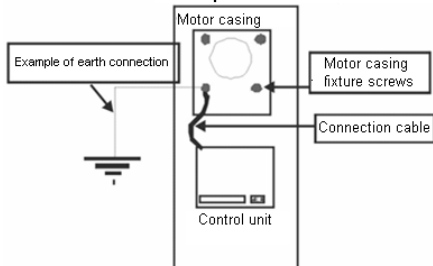

Any contact which is Normally Closed (N.C.) Must be bridged to the common if not used.

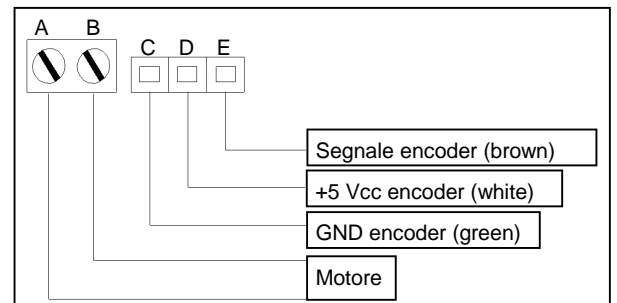
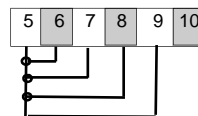

Note: Correspondance colours valid only for **BAS** motor.

IMPORTANT: to obtain a correct working of the accessories (photo devices in particular) connected to the control box, is very important that the entire system (motor+ control box) has a single mass reference system. You must therefore connect a small cable between the motor casing and the control box at the point shown in the figure. If there is a good ground connection it is advisable to connect it to the system.

4. Settings



This chapter contains important information for a sure and correct installation. Follow scrupulously all the instruction, because a wrong installation can provoke breaks or malfunctioning of the automatism.

Warning: Before starting the programming of the control unit, desactive all the locks of the door (Unlocked handle, open lock)

4.1 Preliminary checks.

Before powering up the control panel, check the wirings. In particular check that there are no damaged wires, short-circuits between wires and that all the accessories are connected to the terminal board in the points indicated in the diagram on the previous page.

Once the power supply is on check that:

1. Check that there are no excessive frictions; to this proposal unlock the slide and manually move the door in opening and in closing with the necessary precautions, bringing it on the anchorage point of the staff to the lock itself.

The force necessary to move this action does not have to exceed the Kg.15.

2. The POWER LED is constantly on.
3. Check that the radio module is inserted and working.
4. Check the motor and the encoder connections by following the procedure described below:

This procedure allows us to check the rotation sense of the motors, any possible blockages during the movement of the wing. It is important to carry out this check in order to locate any wiring errors or anything else that can jeopardize.

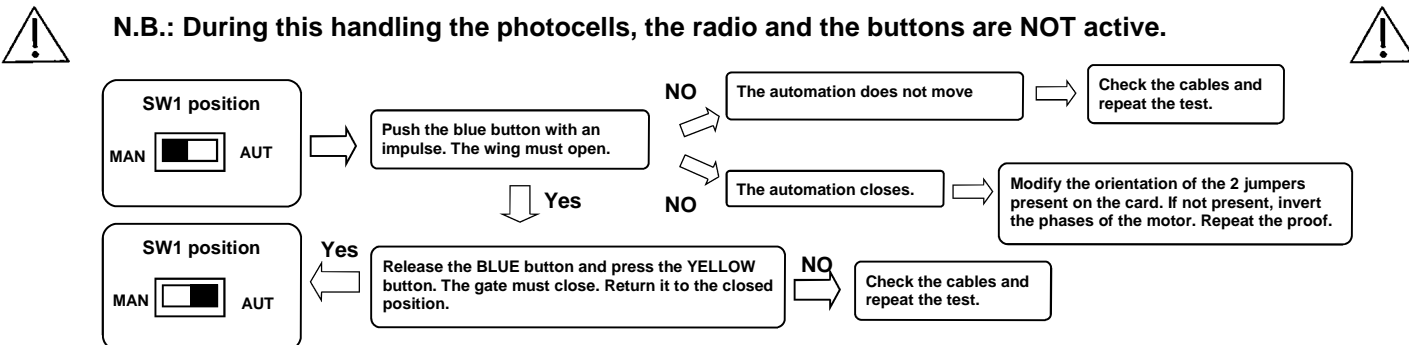

4.2 Manual moving

This procedure must be carried out only by the installer and only during the setting up of the system. This moving must be effected only in particular situation, in which is not possible to bring back the door in closing position in automatic mode.

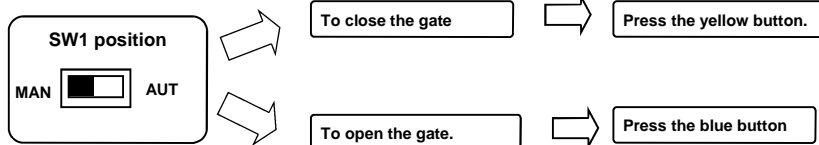

WARNING: the reactivation of the automatic mode (AUT) implies the use of the reached position as totally closing position.
WARNING: During the manually moving, the anti-squashing safety is excluded.

4.3 Memorisation of the transmitters (only with closed door).

Memorize almost one 1-button transmitter. The control unit is provided of rolling code decoding, to vary the decoding type (see paragraph 5.3.) During the normal functioning, the first button memorized, execute the step-by-step function (opening and closing), the second button (optional) manages the starting function of the turning on of the courtesy light.

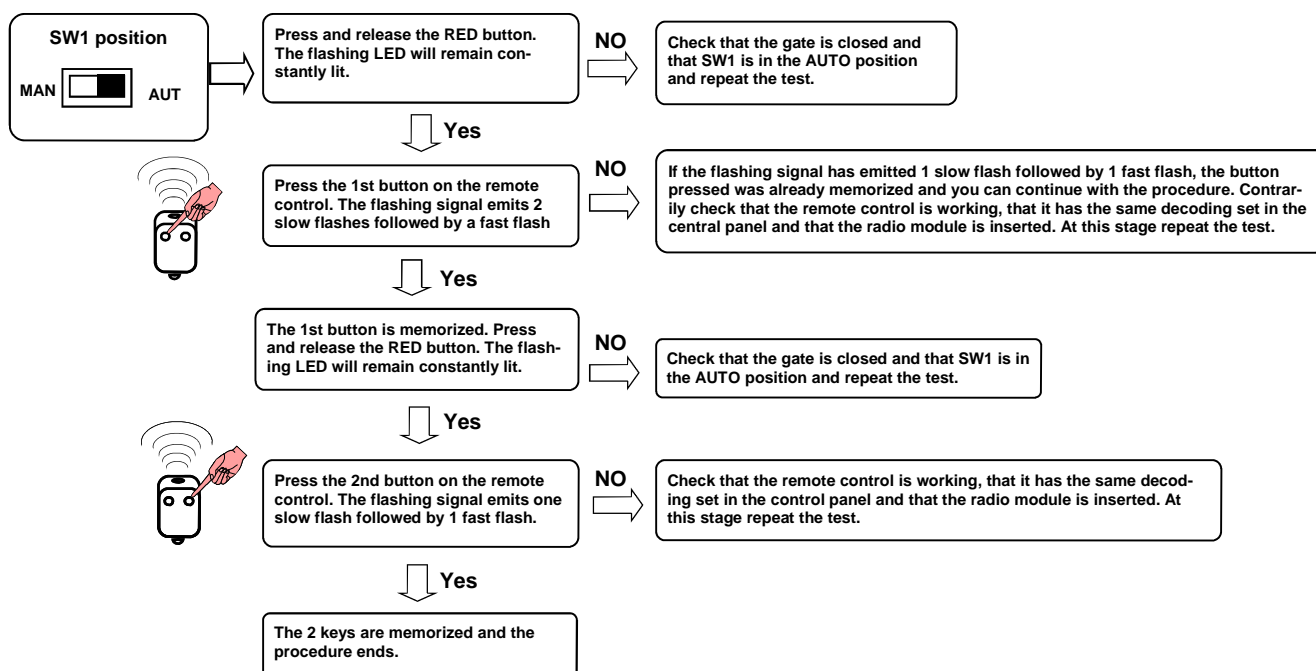

4.4 Setting the gate movement.

This procedure must ONLY be carried out by an installer and ONLY during setting up of the system. For correct setting, before carrying out alterations, bring the gate to the completely closed position (see paragraph 4.2).

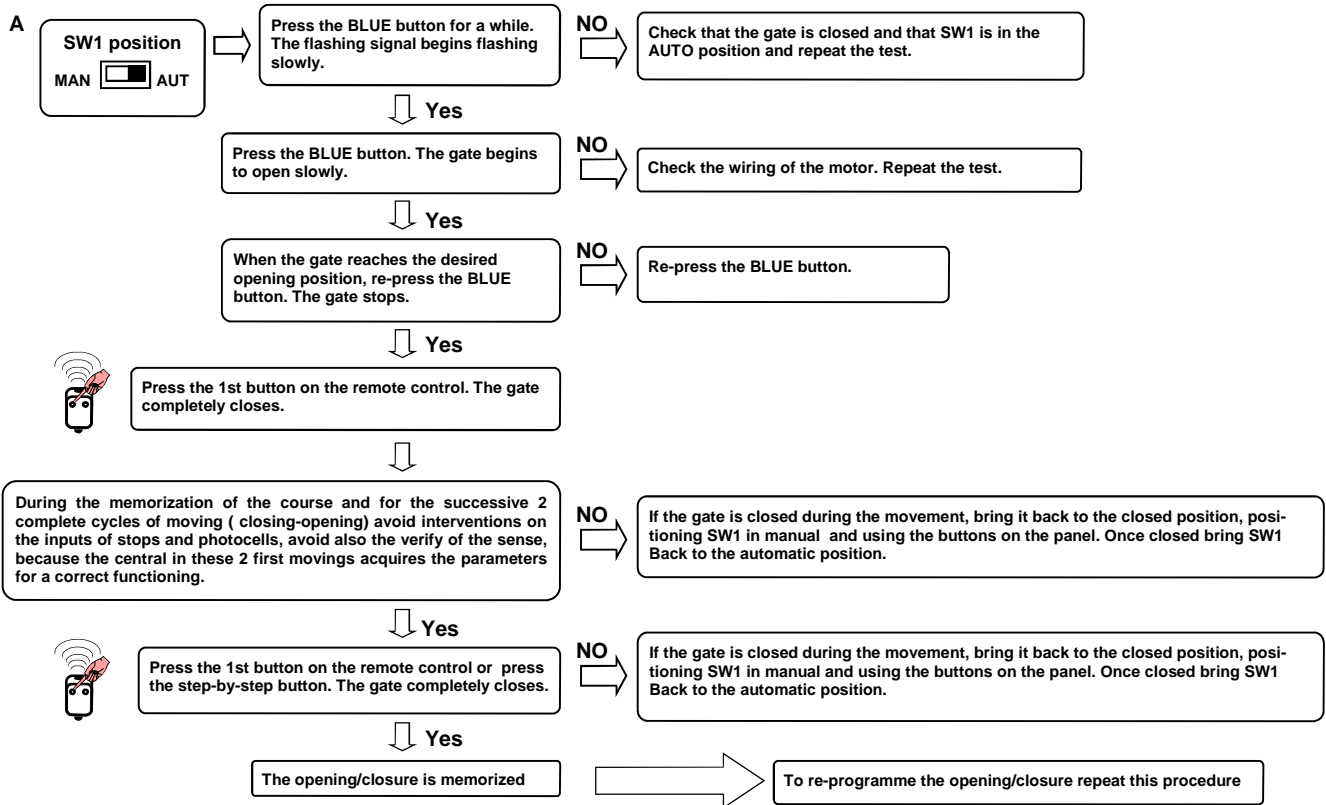

4.5 Regulating the anti-squashing security

This procedure must ONLY be carried out by an installer and ONLY during setting up of the system. For correct setting, before carrying out alterations, bring the gate to the completely closed position (see paragraph 4.2). To obtain a correct functioning, the gate must move manually with a force inferior to Kg 15.

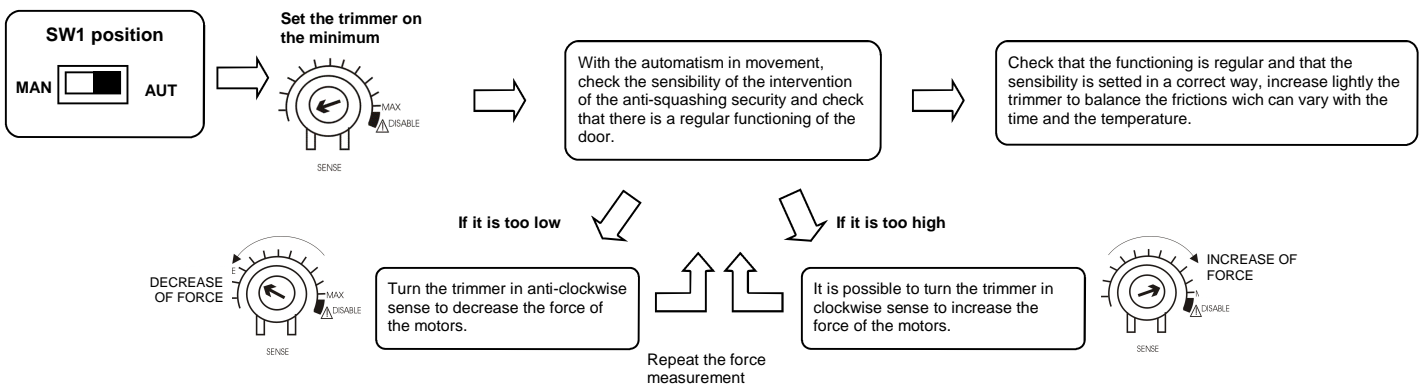

Warning: With the trimmer in disabled position (flashing light turn on), the anti-squashing security is excluded.

4.6 Regulation of the automatic re-closure time

This procedure must ONLY be carried out by an installer and ONLY during setting up of the system. For correct setting, before carrying out alterations, bring the gate to the completely closed position (see paragraph 4.2).

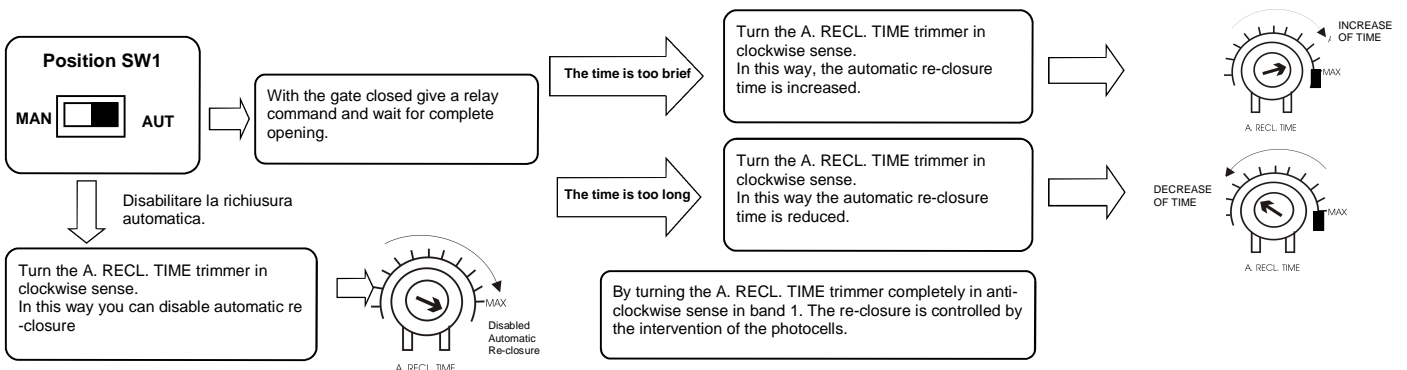

4.7 Resynchronization

This operation must be done only in case if it is repeatedly observed that the door doesn't reach the correspondent position of reclosing (or if it tends to exceed it), or in case you find yourself in the conditions described at point 4.8.

The operation of resynchronization consists on the activation in closure of the door at reduced velocity, with the intent to find the point of total closure; the moving arrests automatically on the point in which you find a mechanical stop that hampers the movement. This point is identified like position of closure.

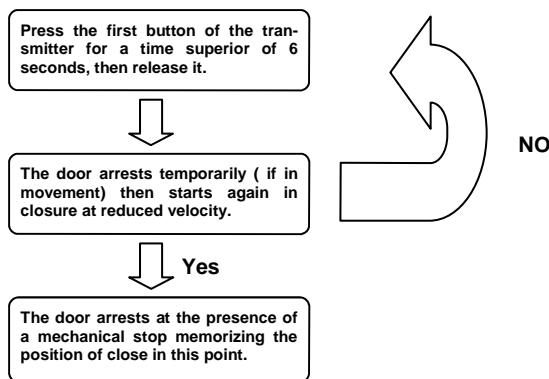

Warning: During the operation of resynchronization, the intervention of the anti-squashing security is interpreted like identification of the closing position. To avoid the voluntary intervention the sensibility of the self results remarkably reduced respect to the conditions of normal functioning.

4.8 Unblocking of lock.

In case of opening of the door with the lock inserted, you have the intervention of the security which involves the arrest of the door. A successive restart of the moving, for reasons of safety, happens only in the opening direction. In this case, it is possible that the lock rests blocked cause of the tension exercised by the door. If it happens, it is advised to resort to the operation of resynchronization (point 4.7).

5. Advanced functions.

This procedure must be carried out ONLY by an installer and ONLY during setting up of the system. For correct setting, before carrying out alterations, bring the gate to the completely closed position (see paragraph 4.2).

5.1 Reset.

In case if it is necessary to reset the control unit proceed as follows: (total erasing of the memory and deactivation of all the functions):

1. Remove power supply from the system.
2. Set the selector SW1 on AUT (automatic).
3. Press the red button.
4. Keep it pressed while the power supply is reconnected to the system.
5. Keep it pressed until the flashing signal lights up for the 3rd time.
6. Release the buttons. At the end of the programming the flashing signal turns off. The reset is done.

5.2 Deleting of a singular transmitter (only with rolling code decoding).

In case if it is necessary to cancel a singular transmitter, proceed as follows:

1. Set the selector SW1 on AUT (automatic).
2. Push the hidden button of a transmitter already learned, or push the red button of the control unit; the flashing lamp turn on.
3. Push the hidden button and at the same time the first button of the transmitter that you want to cancel, the flashing turn on and the deletion is complete.

5.3 Selection of the type of decoding and total deleting of memory.

In case if it is necessary to change decoding mode (from fixed mode to rolling code mode or vice versa) or erasing all the transmitters learned, proceed as follows:

1. Remove power supply from the system.
2. Set the selector SW1 on MAN (manual).
3. Press the blue + red button at the same time if you want fixed code decoding or press only the red one if you want the rolling code decoding.
4. Keep them pressed while the power supply is reconnected to the system.
5. Keep them pressed until the flashing signal lights up for the 3rd time.
6. Release the buttons. At the end of the programming the flashing signal turns off. Set the selector SW1 on AUTO. The selection of the type of decoding and the total erasing of the memory are done.

Note: This practice executes a total deletion of the memory of the control unit. So you have the complete deletion of the parameters previously memorized (course of the gate, memorized transmitters) and the disconnection of the pre-flashing function. Set the codification mode as first point, before any other programming.

To re-programm the course it is not necessary to reset the memory!!!!

6. Enabling and disabling the pre-flashing, photocell test and condominium function.

To modify the status of any of these functions it is necessary to enable the setting mode. In the phase of learning, the central automatically slides the functions in which it is possible to intervene. The led of the flashing light signals the selected function each time with a variable number of flashings. The passage from a function to another one is executed automatically (is enough to maintain always pressed the red button). The central starts selecting the first function (signaled by 1 flashing), successively, keeping pressed the red button you pass at the second function (signaled by 2 flashings) and so on. To enable the setting / learning mode proceed as follows:

1. Close completely the door.
2. Press the red button and keep always pressed the red button.
3. After 4 - 5 seconds the led of the flashing - light executes a series of 8 flashings (that notifies the next entry of the setting mode). Once ended the series of flashings the control unit is on setting mode. Do not release the button yet.
4. Once individualized (through the number of flashings of the flashing-light led) the function that you want to modify, release the red button. In this way the wishing function is selected. Once selected the function, the central puts in evidence the setting by flashing with a slow frequency (1 flashing /second) or with a rapid frequency (2 flashings / second) as pointed out on the next table:

| No. of flashes | Selected function | Flash | Yellow button | Blue button |
|----------------|---------------------|----------------|---------------|--------------|
| 1 | Pre-flashing | Slow= disabled | activation | deactivation |
| 2 | Photocell Test | Fast= disabled | activation | deactivation |
| 3 | Condomonium setting | Slow= disabled | activation | deactivation |
| 4 | Reserved | | | |
| 5 | Reserved | | | |
| 6 | Reserved | | | |

5. Then press the button (see table) corresponding to the new status you wish set for the selected function. The frequency of flashing will vary according to the chosen mode.

At this point it is possible to modify further functions or, if you have finished, go out from the setting phase. In case of you want to modify other functions, press and keep pressed the red button. After few seconds, the central will start again to select in sequence the several function. Then proceed like explained over. Instead if you want to exit from the learning mode, it is sufficient to bring the lever of the selector Sw1 in manual position, wait 1-2 sec and successively report it in automatic position. In this way, the central gets out of the learning mode and prepares itself for the normal functioning.

6.1 Pre-flashing: The gate motion is always signaled by a pre-blink, advising the user that the gate is ready to start.

6.2 Condomonium function: During the opening phase of the gate, every command is ignored. Once opened the door, it is possible to close it using the step-by-step command or using the automatic re-closure. During the closing phase, a step-by-step command blocks and inverts the movement.

6.3 Photocell test: Every time the motor is switched on, the control unit automatically controls if the photocells are functioning properly. This operation increases the security system if a photocell is damaged (for instance output relay stuck) or in case of undesired photocell input short circuit. This test is executed after the control unit has received an order of "moving", but before power is applied to the motor.

7. Problems resolutions

| Type of problem | Probable cause | Solution |
|---|---|---|
| On activating the opening command the automation does not move. | No electrical power supply | Check the presence of the electrical voltage and all the connections to the electrical network. |
| | Burned fuse | Substitute the fuse with a similar one. |
| On activating the opening command the gate moves for a brief time and then stops. | Incorrect encoder connection | Check the wiring of the encoder's wires. |
| On activating the opening command, the automation moves to closure. | Jumper direction motor inverted | Invert the Jumpers. |
| You cannot manage to enter into the remote control programming | The gate is not closed | Close the gate (in the manual). If the gate was closed set selector S1 to manual, wait 1 second and re-set it to automatic. Try again entering into setting mode. |
| You cannot manage to programme the remote controls | The type of set decoding in the control panel does not correspond to the type of remote control in use. | Check which decoding has been set and possibly select that which corresponds to the remote control in use. |
| You cannot manage to enter into the opening/closure programming mode. | The gate is not closed | Close the gate (in the manual). If the gate was closed set selector S1 to manual, wait 1 second and re-set it to automatic. Try again entering into setting mode. |
| The control panel is attached to power supply by the gate does not move. | A normally closed input is not active | Check the photocell, stop and limit switch input. If not used they must be bridged to the common. |

GUARANTEE - In compliance with legislation, the manufacturer's guarantee is valid from the date stamped on the product and is restricted to the repair or free replacement of the parts accepted by the manufacturer as being defective due to poor quality materials or manufacturing defects. The guarantee does not cover damage or defects caused by external agents, faulty maintenance, overloading, natural wear and tear, choice of incorrect product, assembly errors, or any other cause not imputable to the manufacturer. Products that have been misused will not be guaranteed or repaired. Printed specifications are only indicative. The manufacturer does not accept any responsibility for range reductions or malfunctions caused by environmental interference. The manufacturer's responsibility for damage caused to persons resulting from accidents of any nature caused by our defective products, are only those responsibilities that come under Italian law.